

REVISIONS		
DATE	NAME	NUMBER
12/9/88	DOUGLAS R. LONG	PE + LS 16341
12/12/90	IRA J. MILOVSKY	PE & LS 27053
9/23/93	JOHN R. WALKER	PE & LS 10294
1/14/94	JOHN R. WALKER	PE & LS 10294
4/13/95	JOHN R. WALKER	PE & LS 10294

INDEX OF SHEETS	
SHEET NUMBER	BLOCK NUMBERS
5	30,31,32,33,34,35,36,37,38
6	24,39,40,41,42
7	44,45,46,47,48,49,50,51
7.01	1,2,3,4,5,6,7,8,9,10,11,12,13,14,15 16,17,18,19,20,21,22,23,24,25,26 27,28,29,30,31,32,33,34,35,36
7.02	37,38,39,40,41,42,43,44,45,46,47 48,49,50,51,52,53,54,55,56,57,58 59,60,61,62,63,64,65,66,67,68
8	42,43,51
8.01	43
12	57,58,59,60
13	57,58,59
14.01	1,2,3,4
14.02	1,2,3,4,5,6,7,8,9,10,11,12,13,14,15 52,53

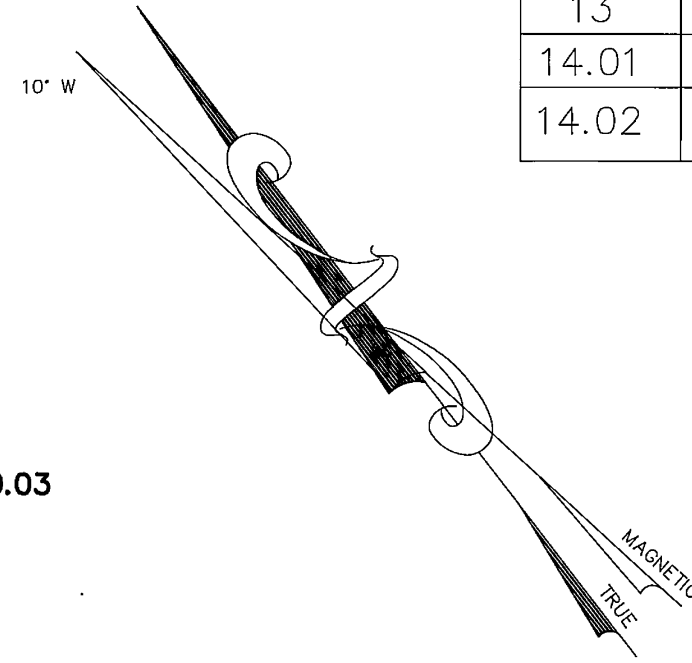
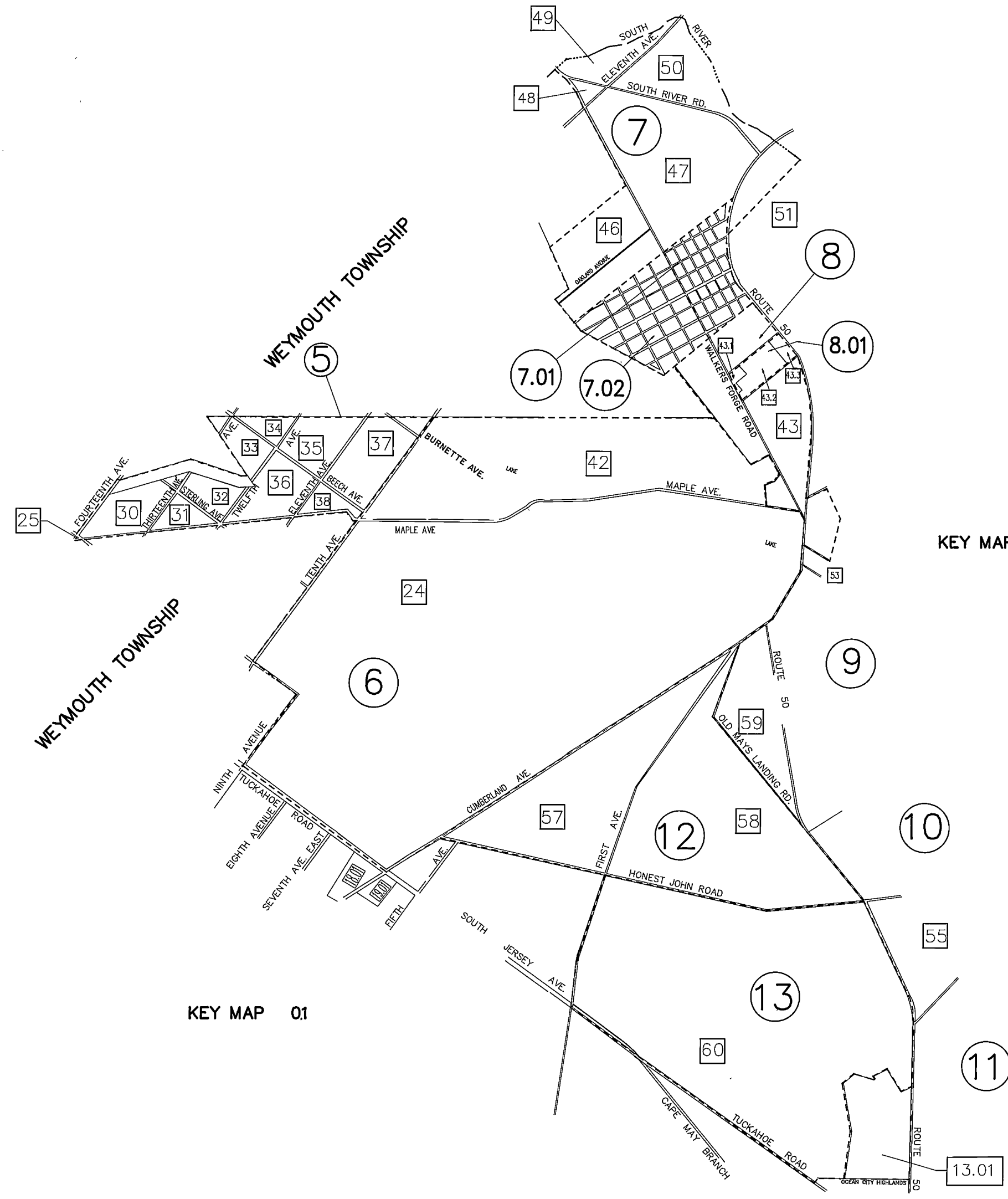

LEGEND

- 2 DETAIL SHEET NUMBER
- 2 BLOCK NUMBER
- SHEET LIMIT
- _____ BLOCK LIMIT

NOTE:
 THE AREAS, BOUNDARIES AND DIMENSIONS, SHOWN ON THIS TAX MAP, ARE DERIVED FROM GROUND SURVEYS, AERIAL SURVEYS, AND RECORDED PLANS, MAPS, DEEDS, WILLS, AND ARE TO BE USED FOR ASSESSMENT PURPOSES ONLY.

1. TO SHOW CONDITIONS AS OF APRIL 1989
2. I HEREBY CERTIFY THAT THIS MAP AND ANY REQUIRED SURVEY HAS BEEN MADE UNDER MY IMMEDIATE SUPERVISION, AND COMPLIES WITH THE LAWS OF THE STATE OF NEW JERSEY.

Douglas R. Long
 DOUGLAS R. LONG, P.E. & L.S.
 NEW JERSEY 16341

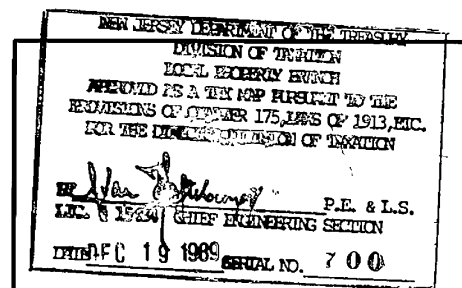

TAX MAP
 CITY OF ESTELL MANOR
 ATLANTIC COUNTY, NEW JERSEY
 SCALE: 1"=1000' APRIL 1989
 DOUGLAS R. LONG, P.E. & L.S.
 LONG ENGINEERING & SURVEYING CO.
 591 N. Black Horse Pike Williamstown N.J. 08094